

# K20 K16



*Digital Knight*  
16x20 and 14x16  
Digital Clamshell



# Table of Contents

Introduction .....	3
Setup & Suggestions .....	4
Basic Use .....	4
Setting Time .....	4
Setting Temperature .....	5
Setting Height / Pressure .....	6
Guidelines & Standard Settings .....	7
Programmable Presets .....	8
User Options Menu .....	9
Fahrenheit / Celsius .....	9
Timer Counter .....	9
Recorded Pressings .....	9
Height Gauge - High Point .....	10
Height Gauge - Low Point .....	10
Pressure / Height Gauge Sensitivity .....	10
Drop Sense .....	10
Beep .....	11
Alarms .....	11
Interchangeable Tables .....	12
Maintenance .....	12
Troubleshooting .....	13
Troubleshooting (cont.) .....	14
Limited Warranty .....	15

# Introduction

Congratulations on your purchase of the DK20 16x20 or DK16 14x16 clamshell press! This heat press machine has many exciting features, all of which are meant to help make your heat transfer pressing endeavors as successful and easy as possible. Please take the time now to thoroughly read through this manual to become acquainted with them. It will explain some key features, concepts and methods that will save much time and effort in using this press and in your heat pressing applications.

Throughout this manual, many areas and components of this machine will be referred to by specific names. Please refer to the illustrations below in order to become familiar with some of the terminology used in this manual.

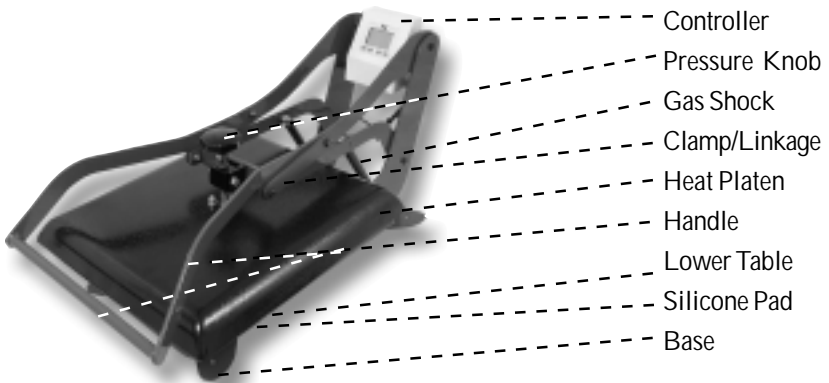

## Default Operating Mode of Controller

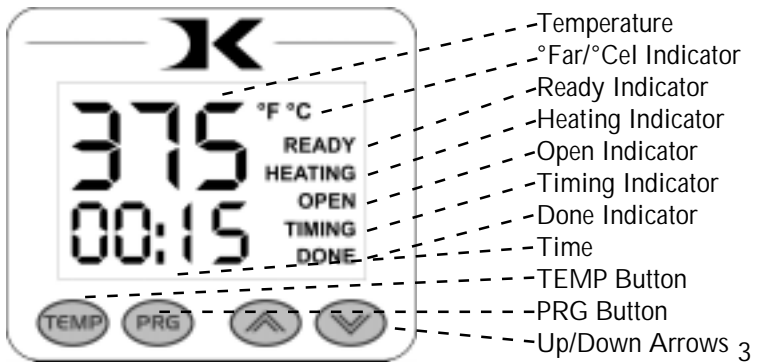

# Setup & Suggestions

- Locate the press on a firm, sturdy work surface. It is recommended that the front two holes on the feet of the machine be bolted down for best ease-of-use.
- The height of the bench/work space the press is located on would be ideally 27" to 32" high.
- Attach the power cord from the rear to the backside of the controller. There is a power inlet on the back panel of the control box for the power cord.
- The press should remain in the unclamped/open position when not in use. Do not leave the heater block closed on the table surface when hot for long periods of time if not using. The top platen may either be open, or fully retracted backwards when not in use.

## Basic Use

### Setting Time

The time setting is always editable in the default operating mode of the controller. The left two digits of the time display are minutes. The right two digits are seconds. This can be changed to Hours/Minutes in the User Options Menu.

- Use the Up & Down arrow keys to change the time.
- Hold the Up or Down arrow key down to increment the values quickly. After a brief pause, the values will accelerate.
- Press the Up & Down arrow keys together to clear the setting to 00:00
- When the press is closed, the timing cycle starts. The "TIMING" indicator will appear.
- When the timing cycle is finished, the "DONE" indicator will appear.
- Depending on the timer alarm chosen, the alarm may continue to sound at the end of the timing cycle until the press is opened.
- When the press is opened up, the "OPEN" indicator will appear.



# Setting Temperature

In the default operating mode of the controller, the displayed temperature is the Current temperature. This is the actual temperature of the heat platen surface. Please note that the operating range of the controller is from 150°F to 550°F (65°C to 288°C). During the first heat up cycle of the press, the controller will display 150°F (65°C) until the heat platen temperature rises above that temperature.

The Set Point temperature is the temperature the operator sets the press for. This is the value the press will regulate the Current temperature based on. The set point temperature may be changed whenever necessary:

- When in the default operating mode, press the TEMP button.
- The Current temperature will be replaced by the blinking Set Point temperature.
- Use the Up & Down arrow keys to change the Set Point temperature.
- Hold the Up or Down arrow key down to increment the values quickly. After a brief pause, the values will accelerate.
- Press the Up & Down arrow keys together to set the temperature to 350.
- When finished setting the temperature, press the TEMP button to return to the default operating mode.



- The control will regulate the heat platen temperature based on the set point temperature. When the temperature falls below the Set Point, the "HEATING" indicator will appear.
- When the temperature reaches the Set Point, the "HEATING" indicator will disappear and the "READY" indicator will appear.
- If the Set Point temperature is set to a temperature below the Current temperature, the press will wait to cool down to that Set Point. At that time, neither the "READY" or "HEATING" indicators will appear.

# Setting Height / Pressure

Pressure is set manually using the large black Pressure Adjustment Knob. There is one important rule of thumb when setting pressure: The press **MUST LOCK IN PLACE** when lowering and clamping the press. Do not simply let the platen rest on the pad. A good solid two-handed locking force is recommended when first doing transfers to insure good results. A “Ka-Thunk” click/clamp sound will result when locking the press in place.

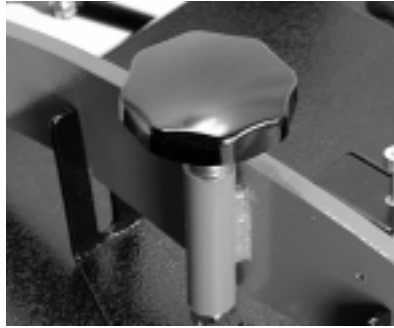

- To decrease the pressure, turn the pressure knob to the right, clockwise.
- The top head will rise away from the lower table.
- To increase the pressure, turn the pressure knob to the left, counter-clockwise.
- The top head will lower toward the pressing table.

**CAUTION:** The heat platen will become detached from the frame and drop onto the table if it is adjusted too far. Please use caution when turning the knob to the left (unscrewing: counter-clockwise).

# Guidelines & Standard Settings

The following information covers some basic guidelines for pressing, as well as some generic parameters for basic heat transfer applications.

- When pressing shirts, it is often recommended that the shirts be quickly pressed for 2 seconds before transferring to remove wrinkles and water content.
- When pressing two sides of a garment, pull the garment over the table so that the printed side drapes underneath the table. This will avoid reheating previously transferred designs on opposite sides of garments. It will also avoid any bleed-through of inks on lighter fabrics.
- Avoid laying collars, cuffs, zippers, and other bulky parts of garments on the lower table, as these can adversely affect pressing conditions, and reduce the life of the silicone pad.
- When pressing rigid substrates (plastics, metals, woods, etc.), be sure that any protective films or laminates are removed before heating.
- Always check that the transfer image is face down against the material, to avoid sealing the image against the heat platen instead of the substrate.

Always follow the transfer media suppliers instructions when pressing. The information below is for general reference only, and may not be as accurate as the instructions provided by the transfer media & imprintable substrate supplier.

- |  |   |
|--|---|
| • Hot Split Supplier Transfers         | 350-375°F, 8-10 secs                      |
| • Puff Transfers                       | 350-375°, 5-7 secs (extra heavy pressure) |
| • Ink-Jet Transfer Papers              | 360°, 15-18 secs                          |
| • ColorCopy/Laser Transfer Papers      | 375°, 20-25 secs                          |
| • Sublimation Inks (Polyester Fabrics) | 400°, 35 secs                             |
| • Sublimation Inks (Plastics)          | 400°, 1 min, 15 secs                      |
| • Sublimation Inks (Metals)            | 400°, 1 min                               |
| • Sublimation Inks (Woods)             | 400°, 1 min, 15 secs                      |
| • Sublimation Inks (Ceramics)          | 400°, 4 min                               |

# Programmable Presets

Programmable presets are stored programs where commonly used Temperature, Time and Height (pressure) settings can be stored and retrieved.

Presets can be recalled simply by pressing the PRG key, selecting the program desired with the arrow keys, and pressing the PRG key again. This will update the current settings on the press with the settings in the preset.

Presets can be edited by pressing the TEMP key while inside the programs. When the display shows "SEt", press the TEMP key to change the temperature, time and PRS (height) settings for that preset. The TEMP key moves the flashing value from Temp to Time to PRS and back to "SEt". The arrow keys change the value.

.....

So... the PRG key enters into the presets, and also exits the presets. When exiting the presets, the press' temperature & time is updated with the values that were stored in the preset, and the PRS display tells the operator what height level to adjust the pressure to.

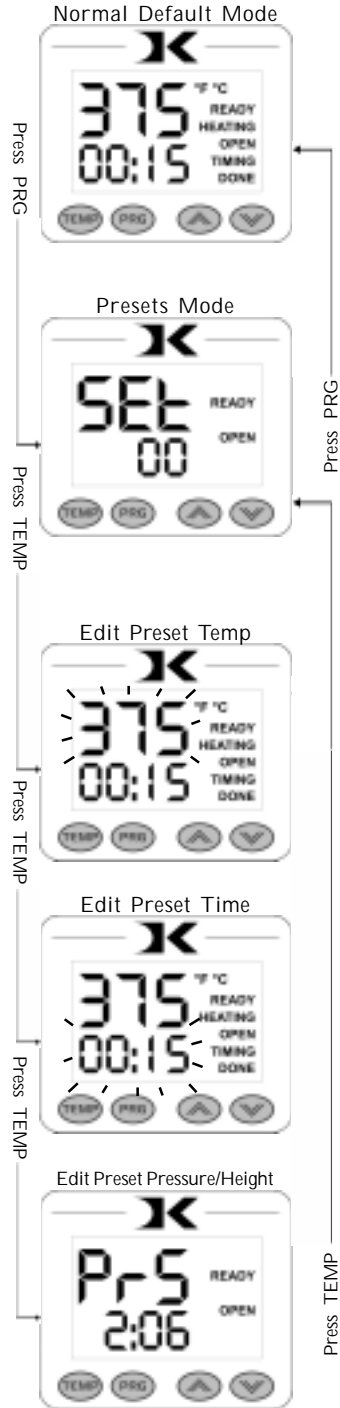



# User Options Menu

The user options menu is a set of features and calibration options that are programmable and adjustable by the user. It consists of a set of menu items that can be scrolled through. Each menu item is a feature whose values can be viewed and /or changed. To enter the user options menu:

- From the default operating mode, press the TEMP & PRG keys simultaneously.
- If the keys are not pressed exactly at the same time, you may enter the temperature edit mode, or the presets mode. Exit either of those modes and try again.
- To cycle from one menu item to the next, press PRG.

## Fahrenheit / Celsius

The Current, Set Point, and Preset temperature values can be displayed in Fahrenheit or Celsius. To change the value to F or C, use the arrow keys. Press PRG to move to the next menu item.



## Timer Counter

The timer displays as factory default Minutes:Seconds. This can be changed to Hours:Minutes. To change to value to HR (hours:mins) or MIN (mins:secs), use the arrow keys. Press PRG to move to the next menu item.



## Recorded Pressings

The digital control records the number of pressing cycles completed. This can be very helpful when counting the number of full pressings that have been performed. The value will scroll from left to right. A "-" sign will separate the beginning and end of the number. To reset the count to Zero, press an arrow key. Press PRG to move to the next menu item.



## Height Gauge - High Point

This feature is not applicable on this press.  
Press PRG to skip this menu item.



## Height Gauge - Low Point

This feature is not applicable on this press.  
Press PRG to skip this menu item.



## Pressure / Height Gauge Sensitivity

This feature is not applicable on this press.  
Press PRG to skip this menu item.



## Drop Sense

A temperature alarm is available for warning the user of out-of-range temperature conditions. The user can set this menu item to sound an alarm if the heat platen drops below the Set Point temperature by the amount indicated. This can be helpful when pressing substrates that absorb an unusually large amount of heat, causing the platen to fall in temperature quickly. If the results of the transfer begin to deteriorate, the Drop Sense feature can help the user avoid this.

Use the arrow keys to set the degrees or to turn this feature off. If the Current temperature drops below the Set Point by this amount or more, an alarm will sound. The default value is OFF.



# Beep

Normally, all buttons on the keypad beep when pressed. This can be turned off, so all button keypresses are silent. Use the arrow keys to turn this feature On or Off.



# Alarms

There are 10 different alarms available to choose from. These alarms are sounded at the end of the timing cycle, as well as if the Drop Sense feature is enabled.

Use the arrow keys to change the values or to turn the alarm off. Please note the different alarms below.



- denotes a short beep.
- \_ denotes a longer beep.
- ~ denotes infinite loop.

Alarm #	Alarm Pattern
Off	No alarm
01	••• _
02	••• _ ~
03	•• _
04	•• _ ~
05	•••
06	••• ~
07	_ ~
08	_
09	•
10	• (shorter)

# Interchangeable Tables

The lower table on the machine is interchangeable. Different sized optional tables can be obtained for various materials & handling requirements.

The tables simply fit right onto the table support. The sides of the angle brackets on the underside of the table will slide along the sides of the square tubing of the table support. Make sure the small bar strip falls inside the table support tubing.

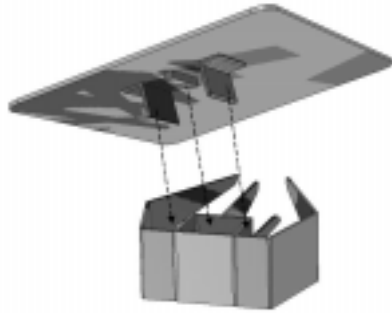

## Maintenance

The majority of the press has been designed to be as maintenance free as possible. There are only a few aspects of the machine that should be monitored to insure proper operation.

- The pressure adjustment screw is the area of greatest wear and stress on the machine and should be checked occasionally for loss of threading. Detach the heat platen from the frame by turning the knob to the left, counterclockwise, and check the threads of the pressure screw and the pressure block it screws into.
- Check the cord regularly to make sure there are no visible signs of damage. Make sure the modular cord does not come in contact with the heater.
- The silicone pad on the lower table can degrade after much use and over an extended period of time. This pad is replaceable. If the pad becomes dried out, cracked, or there are chunks removed from the silicone pad, this can result in inconsistent and poor quality transfers.

# Troubleshooting

The following information attempts to address the most probable mechanical and user issues with the press. Most issues with heat transfer presses are application related. That is, they have to do with the results of a particular transfer application.

For technical support on problems having to do with the final results of a particular transfer paper or media, please contact the supplier of that transfer media. Generally, the machinery manufacturer is unable to support the myriad of different transfer papers, inks and imprintable items on the market from other resellers.

- Q. The timer does not start when I close the heat platen, or the timer does not reset when I open the press up.
- A. There are several probable causes for this. The timer is activated by a micro-tilt-sensor stuck to the pressure arm. First: When the head of the machine is opened, the tilt sensor needs to be tilted slightly upward to signal the controller to stop/reset. When the head of the machine is closed, the timer sensor needs to be tilted downward (towards the floor) to signal the controller to start counting. Second: Check the wire connection from the tilt sensor into the control panel. The timer & pressure signals go to a small black 6-pin connector on the top of the circuit board in the control box. Check to make sure this is firmly seated and plugged into the board.
- Q. The control displays Err when it first comes on, and I can not set the temperature or use the press.
- A. The Err message will display if the heating signal from the platen has been cut off, interrupted, or the heating sensor has failed. First check the green heat connector that plugs into the digital control. This is inside the top head. Open up the control box and unplug the green connector at the top of the circuit board. This is the temperature sensor wire. Remove the two wires from the green plug, cut & strip them for fresh connections, and reconnect them to the green plug. **DO NOT SWITCH** the leads - they must go to the same location on the green plug. Make sure the wires can not be pulled out of the green plug and then reconnect the green plug to the circuit board. Contact the factory if the Err message continues.

# Troubleshooting (cont.)

- Q. I press the keys on the keypad, and there is no sound or response from the controller.
- A. Check the connection of the keypad to the controller. This is inside the top panel. Unplug the power cord. Remove the two screws in between the clamp/linkage that hold down the top panel, and carefully lift the panel up and look inside at the digital controller. The keypad connector passes in through the top panel. It should wind around the first circuit board and be seated fully into the connector. Check the black keypad connector that plugs into the circuit board to see if it has pulled apart. Also check the area where the keypad connects to the front membrane to see if the leads have been damaged. The membrane keypad may need to be replaced.
- Q. The gas springs are not lifting the head as easily as when the press was new, or the gas springs have lost their pressure.
- A. After a large volume of use, and over an extended period of time of many, many pressing cycles, the gas springs will slowly loose their original force. These hydraulic lifter springs are extremely easy to replace, and are a surprisingly similar or even lower cost than conventional mechanical springs. Contact the factory for replacement gas springs if it is not able keep the platen open. The gas springs must have the silver rod Face Down, and the black tube Face Up.
- Q. The press has shut off, and will not come back on after checking the power cord.
- A. Test for power coming from the back side of the power cord inlet socket. Test for power coming from the back side of the on/off switch. Test for power coming to the end of the black & white wires that come from the on/off switch into the control board. This will narrow down which power handling component needs replacement.
- Q. I pressed a transfer upside down. The inks and transfer material have burned onto the heat platen.
- A. Cool the press down. Using a nonabrasive detergent or cleaner, thoroughly scrub the heat platen surface. Do not use steel wool, or a pad that will scratch the Teflon coating of the platen. Test whatever you use to make sure you will not remove the Teflon coating from the heat platen. If you are still unable to remove the transfer material, obtain teflon heater block cleaner from the contact information located at the end of this manual.

# Limited Warranty

Geo Knight & Co warrants that the press is free from defects in both material and workmanship One Year from the date of invoice to the buyer. If any parts or workmanship are found to be defective in manufacture, Geo Knight & Co will repair or replace the defective parts or workmanship. In addition, Geo Knight & Co warrants that the Digital Knight heat control is free from defects in both material & workmanship and is covered under no-charge support for (3) years. Geo Knight & Co also warrants that the heating element is warranted for the lifetime of the press, provided it is owned by the original purchaser. This lifetime warranty on the heating element does not cover temperature sensor failure, damage or disconnection. This warranty covers all parts to repair the defects, except when damage results from accident, alteration, misuse or abuse, or when the machine has been improperly installed, or modified in any way. If the press becomes defective during the limited warranty period of one year for the entire press, three years for the control, or the lifetime of the heating element, Geo Knight & Co reserves the right to recall the defective press to the factory for repairs if on site component replacement is deemed not possible by Geo Knight & Co. A return authorization must be granted by Geo Knight & Co prior to its return.

If a press covered by the one year limited warranty must be returned to the factory for repairs, Geo Knight & Co shall make every effort to repair buyer's press. However, Geo Knight & Co reserves the exclusive right to determine whether to repair or replace a defective press. If Geo Knight & Co authorizes a replacement press, the warranty of the replacement press shall expire on the anniversary date of the original machine's invoice to the buyer.

There are no warranties which extend beyond the description on the face hereof. Seller disclaims any implied warranty of merchantability and/or any implied warranty of fitness for a particular purpose, and buyer agrees that the goods are sold "as is". Geo Knight & Co does not warrant that the functions of the press will meet the buyers requirements or expectations. The entire risk as to use, quality and performance of the press lies with the buyer. In no event will Geo Knight & Co be liable for any damages, including loss of profits, destruction of goods or any other special, incidental, consequential or indirect damages arising from the use of the press or accompanying materials. This limitation will apply even if Geo Knight & Co or its authorized agent has been advised of the possibility of such damage.

Geo Knight & Co Inc  
52 Perkins St, Brockton MA 02302 USA  
(508)588-0186 - Fax (508) 587-5108  
info@heatpress.com - www.heatpress.com

