

K20S



Digital Knight
16x20 Digital Swinger



Table of Contents

Introduction	3
Setup & Suggestions	4
Basic Use	4
Setting Time	4
Setting Temperature	5
Setting Height / Pressure	6
Guidelines & Standard Settings	7
Programmable Presets	8
User Options Menu	9
Fahrenheit / Celsius	9
Timer Counter	9
Recorded Pressings	9
Pressure / Height Gauge Calibration	10
Height Gauge - High Point	10
Height Gauge - Low Point	10
Pressure / Height Gauge Sensitivity	11
Drop Sense	11
Beep	12
Alarms	12
Interchangeable Tables	13
Maintenance	13
Troubleshooting	14
Troubleshooting (cont.)	15
Limited Warranty	16

Introduction

Congratulations on your purchase of the DK20S 16x20 swinger! This heat press machine has many exciting features, all of which are meant to help make your heat transfer pressing endeavors as successful and easy as possible. Please take the time now to thoroughly read through this manual to become acquainted with them. It will explain some key features, concepts and methods that will save much time and effort in using this press and in your heat pressing applications.

Throughout this manual, many areas and components of this machine will be referred to by specific names. Please refer to the illustrations below in order to become familiar with some of the terminology used in this manual.

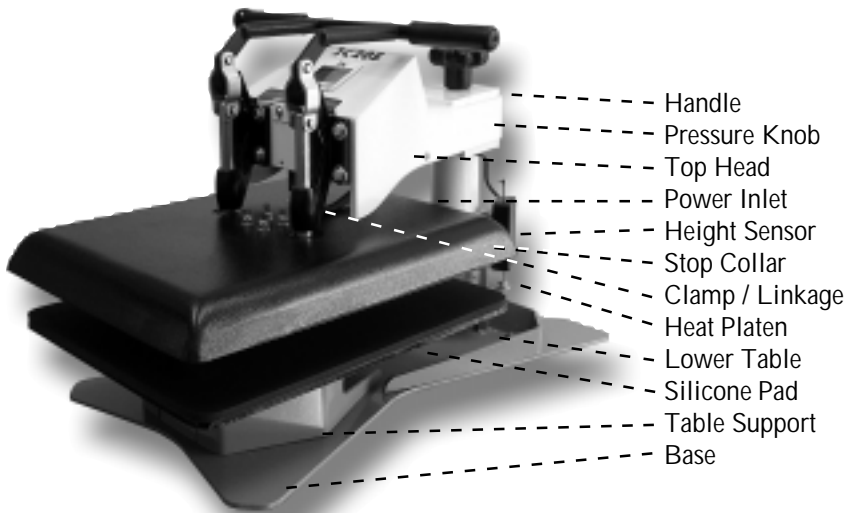

Default Operating Mode of Controller

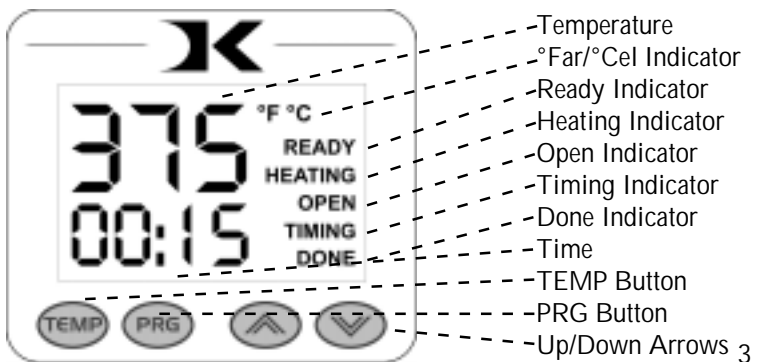

Setup & Suggestions

- Locate the press on a firm, sturdy work surface.
- The height of the bench/work space the press is located on would be ideally 27" to 32" high.
- Attach the power cord from the rear to the underside of the top head.
- There is a power inlet under the top head that the modular cord will plug into.
- Make sure the cord does not interfere with the lower table pressing area, or the height sensor.
- The press should remain in the unclamped position when not in use. Do not leave the heater block closed on the table surface when hot if not using.
- The top head should be swung over and above the pressing table when not in use.

Basic Use

Setting Time

The time setting is always editable in the default operating mode of the controller. The left two digits of the time display are minutes. The right two digits are seconds. This can be changed to Hours/Minutes in the User Options Menu.

- Use the Up & Down arrow keys to change the time.
- Hold the Up or Down arrow key down to increment the values quickly. After a brief pause, the values will accelerate.
- Press the Up & Down arrow keys together to clear the setting to 00:00
- When the press is closed, the timing cycle starts. The "TIMING" indicator will appear.
- When the timing cycle is finished, the "DONE" indicator will appear.
- Depending on the timer alarm chosen, the alarm may continue to sound at the end of the timing cycle until the press is opened.
- When the press is opened up, the "OPEN" indicator will appear.



Setting Temperature

In the default operating mode of the controller, the displayed temperature is the Current temperature. This is the actual temperature of the heat platen surface. Please note that the operating range of the controller is from 150°F to 550°F (65°C to 288°C). During the first heat up cycle of the press, the controller will display 150°F (65°C) until the heat platen temperature rises above that temperature.

The Set Point temperature is the temperature the operator sets the press for. This is the value the press will regulate the Current temperature based on. The set point temperature may be changed whenever necessary:

- When in the default operating mode, press the TEMP button.
- The Current temperature will be replaced by the blinking Set Point temperature.
- Use the Up & Down arrow keys to change the Set Point temperature.
- Hold the Up or Down arrow key down to increment the values quickly. After a brief pause, the values will accelerate.
- Press the Up & Down arrow keys together to set the temperature to 350.
- When finished setting the temperature, press the TEMP button to return to the default operating mode.



- The control will regulate the heat platen temperature based on the set point temperature. When the temperature falls below the Set Point, the "HEATING" indicator will appear.
- When the temperature reaches the Set Point, the "HEATING" indicator will disappear and the "READY" indicator will appear.
- If the Set Point temperature is set to a temperature below the Current temperature, the press will wait to cool down to that Set Point. At that time, neither the "READY" or "HEATING" indicators will appear.

Setting Height / Pressure

Pressure is set manually using the large black Pressure Adjustment Knob. There is one important rule of thumb when setting pressure: The press **MUST LOCK IN PLACE** when lowering and clamping the press. Do not simply let the platen rest on the pad. A good solid two-handed locking force is recommended when first doing transfers to insure good results. A “Ka-Thunk” click/clamp sound will result when locking the press in place.

- To decrease the pressure, turn the pressure knob to the left, counterclockwise.
- The top head will rise away from the lower table.
- To increase the pressure, turn the pressure knob to the right, clockwise.
- The top head will lower toward the pressing table.

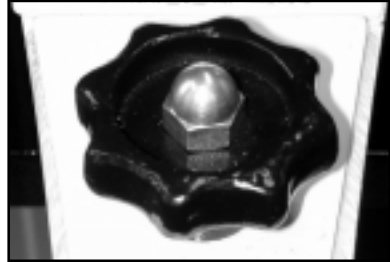

The Digital Height/Pressure gauge is a helpful indicator of the current height of the top head as the operator adjusts the pressure. It does not effect pressure or the operation of the press. It only helps the operator know where they are in regards to height.



- If the pressure knob is turned rapidly enough, the display will change to the pressure gauge display. The units of measure are a relative scale from 0:00 to 10:00, with :02 increments. The top will always display PRS.
- To view the current pressure display value without changing it, simply pull the pin up on the pressure gauge device on the pack post and let it drop back down. This will force the PRS display to appear.

The gauge displays a reference value based on the height of the heat platen in relation to the lower table. The closer the heat platen is to the substrate on the table, the heavier the pressure. The further away, the lighter the pressure. The amount of actual force exerted depends on the thickness of the item being pressed and the distance from the heat platen to the table. The digital height/pressure gauge simply shows a relative value from 0:00 to 10:00 in fine resolution increments as to the current height of the platen.

This helps the user return to an exact pressure setting without the need of multiple experimentations to find the proper pressure setting. By simply changing the pressure until the correct value appears, previous heights and pressure settings for different thickness substrates can be quickly reset without error.

Guidelines & Standard Settings

The following information covers some basic guidelines for pressing, as well as some generic parameters for basic heat transfer applications.

- When pressing shirts, it is often recommended that the shirts be quickly pressed for 2 seconds before transferring to remove wrinkles and water content.
- When pressing two sides of a garment, pull the garment over the table so that the printed side drapes underneath the table. This will avoid reheating previously transferred designs on opposite sides of garments. It will also avoid any bleed-through of inks on lighter fabrics.
- Avoid laying collars, cuffs, zippers, and other bulky parts of garments on the lower table, as these can adversely affect pressing conditions, and reduce the life of the silicone pad.
- When pressing rigid substrates (plastics, metals, woods, etc.), be sure that any protective films or laminates are removed before heating.
- Always check that the transfer image is face down against the material, to avoid sealing the image against the heat platen instead of the substrate.

Always follow the transfer media suppliers instructions when pressing. The information below is for general reference only, and may not be as accurate as the instructions provided by the transfer media & imprintable substrate supplier.

- | | |
|--|---|
| • Hot Split Supplier Transfers | 350-375°F, 8-10 secs |
| • Puff Transfers | 350-375°, 5-7 secs (extra heavy pressure) |
| • Ink-Jet Transfer Papers | 360°, 15-18 secs |
| • ColorCopy/Laser Transfer Papers | 375°, 20-25 secs |
| • Sublimation Inks (Polyester Fabrics) | 400°, 35 secs |
| • Sublimation Inks (Plastics) | 400°, 1 min, 15 secs |
| • Sublimation Inks (Metals) | 400°, 1 min |
| • Sublimation Inks (Woods) | 400°, 1 min, 15 secs |
| • Sublimation Inks (Ceramics) | 400°, 4 min |

Programmable Presets

Programmable presets are stored programs where commonly used Temperature, Time and Height (pressure) settings can be stored and retrieved.

Presets can be recalled simply by pressing the PRG key, selecting the program desired with the arrow keys, and pressing the PRG key again. This will update the current settings on the press with the settings in the preset.

Presets can be edited by pressing the TEMP key while inside the programs. When the display shows "SEt", press the TEMP key to change the temperature, time and PRS (height) settings for that preset. The TEMP key moves the flashing value from Temp to Time to PRS and back to "SEt". The arrow keys change the value.



So... the PRG key enters into the presets, and also exits the presets. When exiting the presets, the press' temperature & time is updated with the values that were stored in the preset, and the PRS display tells the operator what height level to adjust the pressure to.

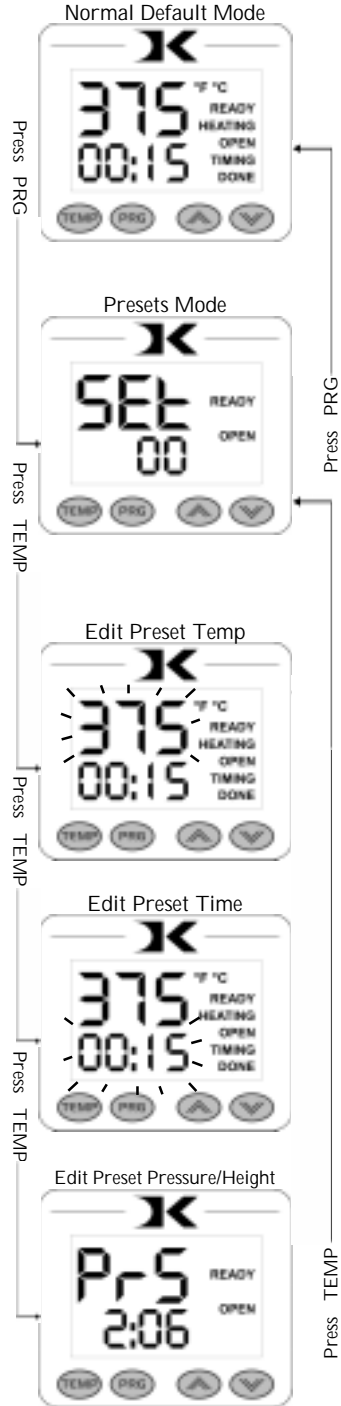

User Options Menu

The user options menu is a set of features and calibration options that are programmable and adjustable by the user. It consists of a set of menu items that can be scrolled through. Each menu item is a feature whose values can be viewed and /or changed. To enter the user options menu:

- From the default operating mode, press the TEMP & PRG keys simultaneously.
- If the keys are not pressed exactly at the same time, you may enter the temperature edit mode, or the presets mode. Exit either of those modes and try again.
- To cycle from one menu item to the next, press PRG.

Fahrenheit / Celsius

The Current, Set Point, and Preset temperature values can be displayed in Fahrenheit or Celsius. To change the value to F or C, use the arrow keys. Press PRG to move to the next menu item.



Timer Counter

The timer displays as factory default Minutes:Seconds. This can be changed to Hours:Minutes. To change to value to HR (hours:mins) or MIN (mins:secs), use the arrow keys. Press PRG to move to the next menu item.



Recorded Pressings

The digital control records the number of pressing cycles completed. This can be very helpful when counting the number of full pressings that have been performed. The value will scroll from left to right. A "-" sign will separate the beginning and end of the number. To reset the count to Zero, press an arrow key. Press PRG to move to the next menu item.



Pressure / Height Gauge Calibration

The digital pressure/height gauge is calibrated from the factory to recognize the lowest and highest pressure points settable on the press. By defining the highest and lowest points of adjustment, the controller is then able to accurately calculate and display the current heat platen height & pressure as the operator turns the pressure knob.

It may become necessary to recalibrate the digital pressure/height gauge if the displayed values of 00 through 10:00 do not properly correspond to the lowest and highest pressure adjustment levels. This could happen if the stop collar is loosened to adjust the stopping position of the heat platen over the lower table. Other factors may also require the user to redefine the highest and lowest points of pressure adjustment to the controller.

This is done very easily through the following User Options Menu items:

Height Gauge - High Point

Turn the pressure knob to the left to raise the top head. Do this until the highest level is reached, without unscrewing the internal bolt from the main post. Press an arrow key to lock in that pressure value to PRH. The high point of the pressure/height gauge is now defined. Press PRG to move to the next menu item.



Height Gauge - Low Point

Turn the pressure knob to the right to lower the top head. Do this until the lowest level is reached. Press an arrow key to lock in that pressure value to PRL. The low point of the pressure/height gauge is now defined. Press PRG to move to the next menu item.



Pressure / Height Gauge Sensitivity

The PRR menu item allows the user to define how sensitive the height gauge is for displaying purposes. This setting defines how quickly the pressure display will appear during normal operation. The lower the sensitivity setting, the less the amount of change is required when turning the pressure knob to cause the PRS display to appear during the default operating mode. The higher the number, the greater the amount of change in height is required to display the PRS value.

Usually a setting of 02 is fine for normal operation. However, sometimes merely closing the press can cause the pressure/height gauge to register a reading and change the display to the PRS reading undesirably. By increasing this value, the PRS display will not activate from smaller changes to the pressure. Conversely, sometimes the operator may adjust the pressure knob, but the PRS value does not display unless the knob is turned very quickly. By lowering the value, the display will activate based on smaller and slower changes to the pressure setting.

Use the arrow keys to change the PRR sensitivity setting. Press PRG to move to the next menu item.



Drop Sense

A temperature alarm is available for warning the user of out-of-range temperature conditions. The user can set this menu item to sound an alarm if the heat platen drops below the Set Point temperature by the amount indicated. This can be helpful when pressing substrates that absorb an unusually large amount of heat, causing the platen to fall in temperature quickly. If the results of the transfer begin to deteriorate, the Drop Sense feature can help the user avoid this.

Use the arrow keys to set the degrees or to turn this feature off. If the Current temperature drops below the Set Point by this amount or more, an alarm will sound. The default value is OFF.



Beep

Normally, all buttons on the keypad beep when pressed. This can be turned off, so all button keypresses are silent. Use the arrow keys to turn this feature On or Off.



Alarms

There are 10 different alarms available to choose from. These alarms are sounded at the end of the timing cycle, as well as if the Drop Sense feature is enabled.

Use the arrow keys to change the values or to turn the alarm off. Please note the different alarms below.



- denotes a short beep.
- _ denotes a longer beep.
- ~ denotes infinite loop.

Alarm #	Alarm Pattern
Off	No alarm
01	••• _
02	••• _ ~
03	•• _
04	•• _ ~
05	•••
06	••• ~
07	_ ~
08	_
09	•
10	• (shorter)

Interchangeable Tables

The lower table on the machine is interchangeable. Different sized optional tables can be obtained for various materials & handling requirements.

The tables simply fit right onto the table support. The sides of the angle brackets on the underside of the table will slide along the sides of the square tubing of the table support. Make sure the small bar strip falls inside the table support tubing.

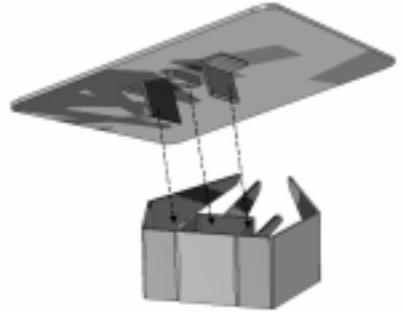

Maintenance

The majority of the press has been designed to be as maintenance free as possible. There are only a few aspects of the machine that should be monitored to insure proper operation.

- The clamp/linkage assembly is the greatest area of wear and friction on the press. The posts that connect to the heat platen should be lubricated with SuperLube - a clear high-temperature lubricant. Do not use grease, white lithium, or WD-40 to lubricate the clamp/linkage assembly.
- Check the cord regularly to make sure there are no visible signs of damage. Make sure the modular cord does not come in contact with the heater. The modular cord should travel from under the head back away from the machine.
- The silicone pad on the lower table can degrade after much use and over an extended period of time. This pad is replaceable. If the pad becomes dried out, cracked, or there are chunks removed from the silicone pad, this can result in inconsistent and poor quality transfers.

Troubleshooting

The following information attempts to address the most probable mechanical and user issues with the press. Most issues with heat transfer presses are application related. That is, they have to do with the results of a particular transfer application.

For technical support on problems having to do with the final results of a particular transfer paper or media, please contact the supplier of that transfer media. Generally, the machinery manufacturer is unable to support the myriad of different transfer papers, inks and imprintable items on the market from other resellers.

- Q. The timer does not start when I close the heat platen, or the timer does not reset when I open the press up.
- A. There are several probable causes for this. The timer is activated by a micro-switch under the head of the press. It is located on a sheet metal bracket with slots. When the head of the machine is opened, the timer's lever should be depressed and the small contact button under the lever should click in. When the head for the machine is lowered, the lever of the timer switch should move down and the contact button click out. The timer switch may need to be loosened and moved along the bracket to a position that allows for the heat platen cover to trigger the switch. When tightening the switch against the bracket, do not overtighten, the switch housing can crack very easily.
- Q. The control displays Err when it first comes on, and I can not set the temperature or use the press.
- A. The Err message will display if the heating signal from the platen has been cut off, interrupted, or the heating sensor has failed. First check the green heat connector that plugs into the digital control. This is inside the top head. Unplug the power cord. Remove the two screws in between the clamp/linkage that hold down the top panel, and carefully lift the panel up and look inside at the digital controller. At the top of the controller, there is a green connector that plugs in. This is the temperature sensor wire. Check to make sure it is properly seated. Be sure not to unplug any other connectors. The temperature wire connects to the center of the rear half of the heat platen. Check this connection as well to see if the connection is correct.

Troubleshooting (cont.)

- Q. I press the keys on the keypad, and there is no sound or response from the controller.
- A. Check the connection of the keypad to the controller. This is inside the top panel. Unplug the power cord. Remove the two screws in between the clamp/linkage that hold down the top panel, and carefully lift the panel up and look inside at the digital controller. The keypad connector passes in through the top panel. It should wind around the first circuit board and be seated fully into the connector. Check the black keypad connector that plugs into the circuit board to see if it has pulled apart. Also check the area where the keypad connects to the front membrane to see if the leads have been damaged. The membrane keypad may need to be replaced.
- Q. The clamp becomes extremely difficult to open and close, and sometimes binds up.
- A. The linkage pins and the posts that connect to the heat platen must be lubricated with SuperLube or Permatex Anti-Seize - a clear, high temperature lubricant. This type of lubricant can be obtained in any auto parts or hardware store. Lower the heater but do not clamp the press. Thoroughly clean the posts that come out of the heat platen, as well as the pins, the holes the pins pass through, and the holes the heat platen posts pass through. Relubricate the posts, pins, and all holes & areas in the clamp assembly that receive motion, and reconnect the assembly.
- Q. The press has shut off, and will not come back on after checking the power cord.
- A. Test for power coming from the back side of the power cord inlet socket. Test for power coming from the back side of the on/off switch. Test for power coming to the end of the black & white wires that come from the on/off switch into the control board. This will narrow down which power handling component needs replacement.
- Q. I pressed a transfer upside down. The inks and transfer material have burned onto the heat platen.
- A. Cool the press down. Using a nonabrasive detergent or cleaner, thoroughly scrub the heat platen surface. Do not use an abrasive scrubber, or a pad that will scratch the Teflon coating of the platen. If you are still unable to remove the transfer material, obtain teflon heater block cleaner from the contact information located at the end of this manual.

Limited Warranty

Geo Knight & Co warrants that the press is free from defects in both material and workmanship One Year from the date of invoice to the buyer. If any parts or workmanship are found to be defective in manufacture, Geo Knight & Co will repair or replace the defective parts or workmanship. In addition, Geo Knight & Co warrants that the Digital Knight heat control is free from defects in both material & workmanship and is covered under no-charge support for (3) years. Geo Knight & Co also warrants that the heating element is warranted for the lifetime of the press, provided it is owned by the original purchaser. This lifetime warranty on the heating element does not cover temperature sensor failure, damage or disconnection. This warranty covers all parts to repair the defects, except when damage results from accident, alteration, misuse or abuse, or when the machine has been improperly installed, or modified in any way. If the press becomes defective during the limited warranty period of one year for the entire press, three years for the control, or the lifetime of the heating element, Geo Knight & Co reserves the right to recall the defective press to the factory for repairs if on site component replacement is deemed not possible by Geo Knight & Co. A return authorization must be granted by Geo Knight & Co prior to its return.

If a press covered by the one year limited warranty must be returned to the factory for repairs, Geo Knight & Co shall make every effort to repair buyer's press. However, Geo Knight & Co reserves the exclusive right to determine whether to repair or replace a defective press. If Geo Knight & Co authorizes a replacement press, the warranty of the replacement press shall expire on the anniversary date of the original machine's invoice to the buyer.

There are no warranties which extend beyond the description on the face hereof. Seller disclaims any implied warranty of merchantability and/or any implied warranty of fitness for a particular purpose, and buyer agrees that the goods are sold "as is". Geo Knight & Co does not warrant that the functions of the press will meet the buyers requirements or expectations. The entire risk as to use, quality and performance of the press lies with the buyer. In no event will Geo Knight & Co be liable for any damages, including loss of profits, destruction of goods or any other special, incidental, consequential or indirect damages arising from the use of the press or accompanying materials. This limitation will apply even if Geo Knight & Co or its authorized agent has been advised of the possibility of such damage.

Geo Knight & Co Inc
52 Perkins St, Brockton MA 02302 USA
(508)588-0186 - Fax (508) 587-5108
info@heatpress.com - www.heatpress.com